

CURB MOUNTED SOLAR ATTIC FAN

The Environmentally Sensible Solution that can SAVE you Money!



Attic venting is an important aspect in maintaining an energy efficient commercial building or warehouse. Proper venting cools the roof, extending the life of the roofing material and reduces the load on the air conditioning system. Powered completely by free solar energy, this sleek and efficient vent is both compact and quiet. The commercial fans are available in 20, 30 or 50 watt models and are powdercoated gray or black. Fully operational right from the box, the installation of the commercial unit requires no electrical wiring, but the unit must be installed on a pre-built curb.

The NEW 50 watt fans have an unmatched venting capacity of up to 3,100 sq. ft. for those larger jobs that require the most powerful and reliable solar attic fan on the market today. The 50 watt fans are powered by a remote solar panel installed directly onto the roof in the location where it will collect the most amount of sunlight.

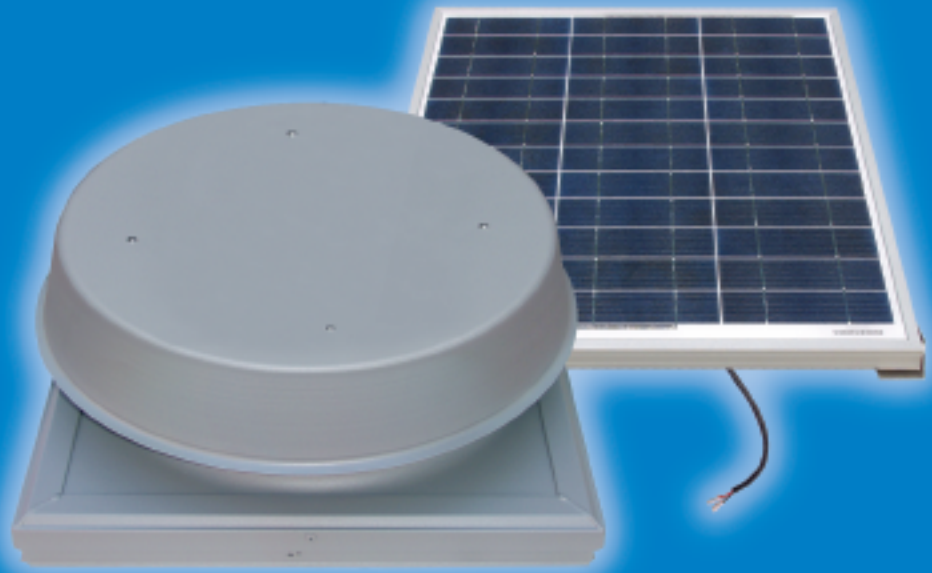

BEST INDUSTRY WARRANTY:
25 YEARS ON THE HOUSING,
SOLAR PANEL AND MOTOR



www.solaratticfan.com

Curb Mounted Solar Attic Fan Technical Specifications

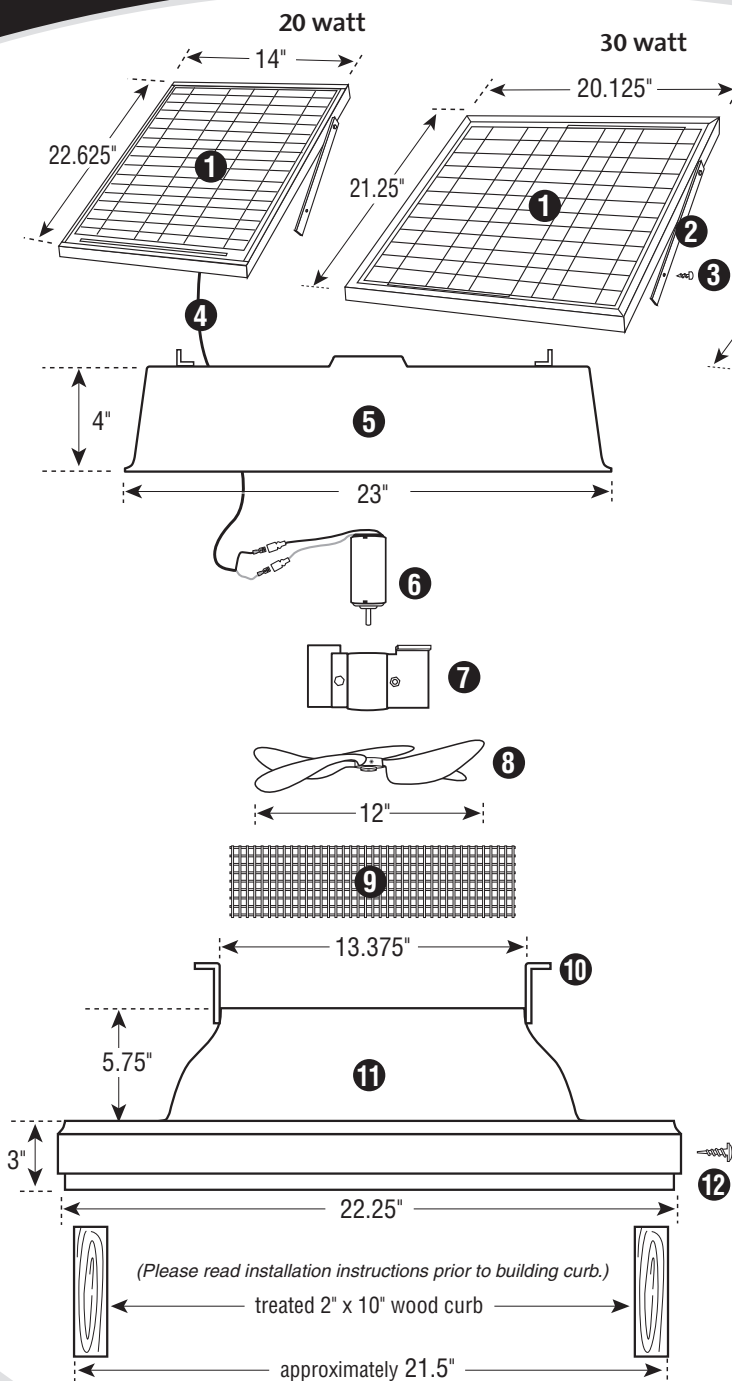

CURB MOUNTED SOLAR ATTIC FAN

NOTE: Exploded view of Curb Mounted Solar Attic Fan is for illustrative purposes only. Unit comes fully assembled.

1. Custom Solar Panel (20 or 30 watt available)*
 2. Adjustable Solar Panel Bracket
 3. (2) #8 x .75" Self-Tapping Screws
 4. Wire Lead
 5. Commercial Pure Grade, 1100 Series Aluminum Shroud
 6. Custom 36V DC Motor
 7. Motor Isolation Bracket
 8. Air Driven Precision Pitch 5 Blade Fan
 9. 3.25" x 48" Stainless Steel Wire Mesh
 10. Rugged 14 Gauge Shroud Support Bracket
 11. Commercial Pure Grade, 1100 Series Aluminum Flashing
 12. (4) #10 x 1.5" Stainless Steel Phillips Head Screws
- *solar panel dimensions may vary slightly

OPTIONAL ACCESSORIES:

Thermal Snap Switch - automatically turns off unit during colder months.

Fire Safety Cutoff Switch - designed to help stop the spread of house attic fires during daytime fan operation by shutting down the fan.

VENTING CAPACITY

- 20 watt unit = up to 2,000 sq. ft. (up to 1,275 cfms)
- 30 watt unit = up to 2,500 sq. ft. (up to 1,550 cfms)
- 50 watt unit = up to 3,100 sq. ft. (up to 1,900 cfms)